



FIRESTOP CENTRE

Authorised New Zealand Distributor
Ph (09) 483 4000 www.firestopcentre.co.nz

AGNI-Wrap in 120mm Concrete Floor/Ceiling Up to 80mm Floor Waste & Socket FRR -/120/120

Step-by-step installation instructions:

1. Ensure the aperture is clean.
2. Install 2x layers of AGNI-Wrap 25 around the pipe allowing a 20mm overlap and position it within the aperture, flush with the surface of the slab.
3. Install 2x layers of AGNI-Wrap 25 around the pipe allowing a 30mm overlap and positioned below the first two layers.
4. Fix AGNI-Wrap 25 with an AGNI-Strap, approx. mid width of the bottom AGNI-Wrap 25.
5. Secure 3x AGNI-Clips equidistant from each other with the hooks going over the AGNI-Wrap 25 using ≥ 32 mm concrete anchors.

Note: Tested with 100mm square floor waste tile with sanitary system plain bend F&F

Technical Information

Substrate	Min. 120mm concrete floor slab
Service type	DN 80mm PVC-U pipe floor waste configuration with socket
Service range	DN 50mm, DN 80mm
Annular gap	Min: 14mm; Max: 19mm
AGNI-Wrap 25 (standard)layers	2 - Inside & 2- outside
AGNI-Clips	3
AGNI-Products	AGNI-Strap, AGNI-Clips, AGNI-Wrap 25
Protection installation	Asymmetrical



System ID# FC861

Compliance Information

Standards	AS1530.4-2014, AS4072.1-2005
FRR/FRL	-/120/120
Reference	RIRF23097 (AP-017)



Agnitek[®]
FIRE RATED TECHNOLOGY

8 Clare St Bayswater
VIC 3153, AUSTRALIA
www.agnitek.com.au

Disclaimer

Agnitek reserves the right to modify product specifications without prior notice due to its ongoing research, development & certification programme. The information in this document is provided in good faith and is intended for guidance purposes only. Any accompanying drawings are solely for illustrative purposes. Since Agnitek cannot oversee installation methods or ensure site conditions, no warranties, expressed or implied, are intended regarding the products' actual performance. We do not accept liability for any loss, damage, or injury from using this information. Please take a look at the test reports displayed on a relevant AGNI-System webpage for all compliance specifics.

Date | 10.05.2024



DN 50mm / 80mm PVC-U pipe floor waste configuration with socket

System ID# FC861

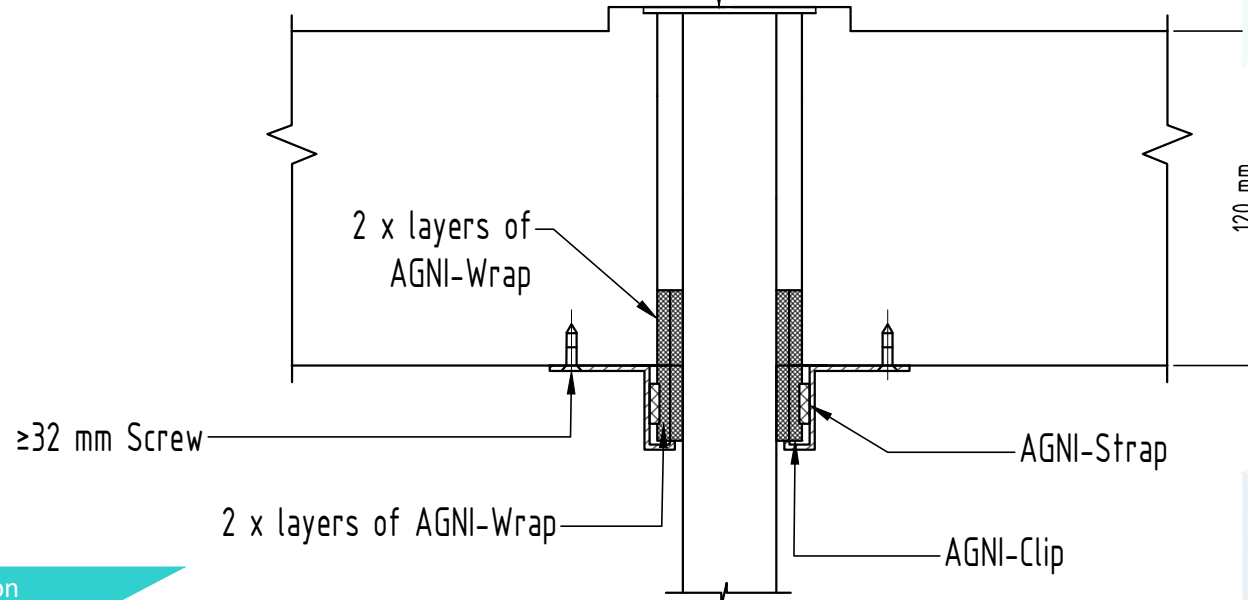

Technical Information

Substrate	Min. 120mm concrete floor slab
Service type	DN 80mm PVC-U pipe floor waste configuration with socket
Service range	DN 50mm, DN 80mm
Annular gap	Min: 14mm; Max: 19mm
AGNI-Wrap 25 (standard) layers	2 - Inside & 2 - outside
AGNI-Clips	3
AGNI-Products	AGNI-Strap, AGNI-Clips, AGNI-Wrap 25
Protection installation	Asymmetrical

Compliance Information

Standards	AS1530.4-2014, AS4072.1-2005
FRR/FRL	-/120/120
Reference	RIRF23097 (AP-017)



Agnitek[®]
FIRE RATED TECHNOLOGY

8 Clare St Bayswater
VIC 3153, AUSTRALIA
www.agnitek.com.au

Disclaimer

Agnitek reserves the right to modify product specifications without prior notice due to its ongoing research, development & certification programme. The information in this document is provided in good faith and is intended for guidance purposes only. Any accompanying drawings are solely for illustrative purposes. Since Agnitek cannot oversee installation methods or ensure site conditions, no warranties, expressed or implied, are intended regarding the products' actual performance. We do not accept liability for any loss, damage, or injury from using this information. Please take a look at the test reports displayed on a relevant AGNI-System webpage for all compliance specifics.

Date | 10.05.2024